



Quality Products & Sales Inc
Orifice Metering Division

PO Box 7

Broken Arrow Ok 74013

Local #(918) 251-0115 * Watts #(800) 444-4634 * Fax #(918) 455-1982

150# SPECTACLE BLIND

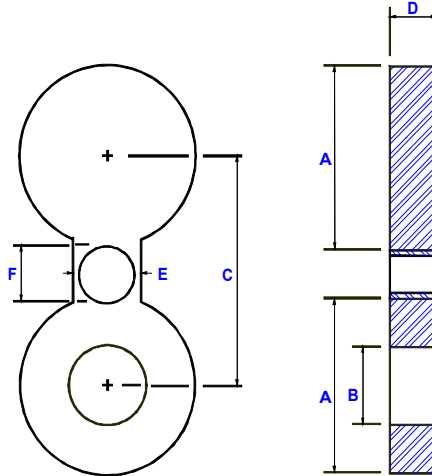

PIPE SIZE	OUTER DIAMETER	BORE	CENTER TO CENTER	THICKNESS	WEB WIDTH	HOLE SIZE	PADDLE BLIND & SPACER HANDL DIMENSIONS
	A	B	C	D	E	F	
1/2	1.75	.62	2.37	.125	1.50	.625	1 x 4
3/4	2.12	.82	2.75	.125	1.50	.625	1 x 4
1	2.50	1.05	3.12	.125	1.50	.625	1 x 4
1-1/4	2.87	1.66	3.50	.250	1.50	.625	1 x 4
1-1/2	3.25	1.90	3.87	.250	1.50	.625	1 x 4
2	4.00	2.38	4.75	.25	2.00	.750	1 x 4
2-1/2	4.75	2.87	5.50	.25	2.00	.750	1 x 4
3	5.25	3.50	6.00	.25	2.50	.750	1 x 4
3-1/2	6.25	4.00	7.00	.375	2.50	.750	1 x 4
4	6.75	4.50	7.50	.375	2.50	.750	1 x 4
5	7.62	5.56	8.50	.375	3.00	.875	1 x 6
6	8.62	6.62	9.5	.500	3.00	.875	1 x 6
8	10.87	8.62	11.75	.500	3.00	.875	1 x 6
10	13.25	10.75	14.25	.625	4.00	1.000	1-1/2x6
12	16.00	12.75	17.00	.750	4.00	1.000	1-1/2x6
14	17.62	14.00	18.75	.750	4.25	1.125	1-1/2x6
16	20.12	16.00	21.25	.875	4.25	1.125	1-1/2x6
18	21.50	18.00	22.75	1.000	4.50	1.250	1-1/2x6
20	23.75	20.00	25.00	1.125	4.75	1.250	1-1/2x6
24	28.12	24.00	29.50	1.250	5.50	1.375	1-1/2x6

MATERIAL: A36, A516-70, STAINLESS STEEL, CHROMOLY, HASTELLOY

OTHER MATERIALS AND STYLES AVAILABLE

Surface Finishes:

Mill (Raw Stock)

Serrated (125Ra Machined Gasket)

Manufactured per ASME B16.48

Paddle Blinds and Spacers Available