



# Quality Products & Sales Inc

## Orifice Metering Division

PO Box 7

Broken Arrow Ok 74013

Local #(918) 251-0115 \* Watts #(800) 444-4634 \* Fax #(918) 455-1982

### ORIFICE PAC

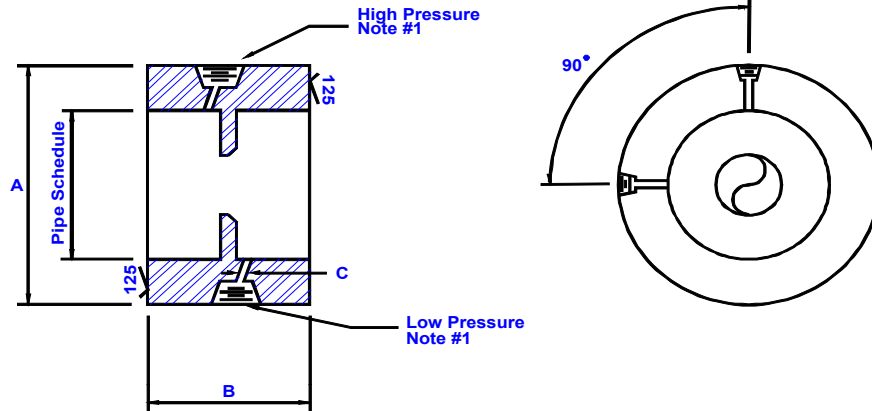

LINE SIZE	150# FLANGE RATING	300# FLANGE RATING	400# FLANGE RATING	600# FLANGE RATING	900# FLANGE RATING	1500# FLANGE RATING	2500# FLANGE RATING	Overall Thickness	Thru Hole Size
	<b>A</b>	<b>A</b>	<b>A</b>	<b>A</b>	<b>A</b>	<b>A</b>	<b>A</b>	<b>B</b>	<b>C</b>
1/2	1.875	2.125	2.125	2.125	2.500	2.500	2.750	1.500	.250
3/4	2.250	2.625	2.625	2.625	2.750	2.750	3.000	1.500	.250
1	2.625	2.875	2.875	2.875	3.125	3.125	3.375	1.500	.250
1-1/2	3.375	3.750	3.750	3.750	3.875	3.875	4.625	1.500	.250
2	4.125	4.375	4.375	4.375	5.625	5.625	5.750	1.500	.250
2-1/2	4.875	5.125	5.125	5.125	6.500	6.500	6.625	1.500	.250
3	5.375	5.875	5.875	5.875	6.625	6.875	7.750	1.500	.250
4	6.875	7.125	7.000	7.625	8.125	8.250	9.250	1.500	.250
6	8.750	9.875	9.750	10.500	11.375	11.125	12.500	1.500	.250
8	11.000	12.125	12.000	12.625	14.125	13.875	15.250	1.500	.250
10	13.375	14.250	14.125	15.750	17.125	17.125	18.750	1.500	.250
12	16.125	16.625	16.500	18.000	19.625	20.500	21.625	1.500	.250
14	17.750	19.125	19.000	19.375	20.500	22.750	*	1.500	.250
16	20.250	21.250	21.125	22.250	22.625	25.250	*	1.500	.250
18	21.500	23.375	23.250	24.000	25.000	27.625	*	1.500	.250
20	23.750	25.625	25.375	26.750	27.375	29.625	*	1.500	.250
24	28.125	30.375	30.125	31.000	32.875	35.500	*	1.500	.250

**MATERIALS: STAINLESS, MONEL, HASTELLOY, TITANIUM, TANTALUM, INCONEL, ALLOY 20**

*Other materials available upon request*

Manufactured to meet  
 A.G.A Report #3  
 A.P.I 14.3.2  
 ASME SPECIFICATIONS  
 I.S.O. SPECIFICATIONS

Calculations available using equations  
 A.G.A. REPORT #3  
 API-2530  
 ASME MFC-3M  
 ISO-5167



*Quality Products & Sales Inc*  
*Orifice Metering Division*

PO Box 7

Broken Arrow Ok 74013

Local #(918) 251-0115 \* Watts #(800) 444-4634 \* Fax #(918) 455-1982

**ORIFICE PAC**

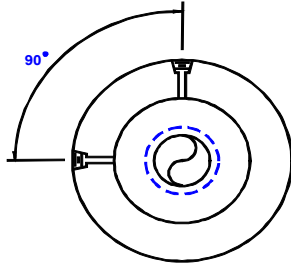

The Concentric Bore & Bevel is the most widely accepted style. The bevel is machined on the downstream side to narrow the bore edge to the appropriate edge thickness.

\* Bore & Bevels are designed for clean gases/vapors and liquids.

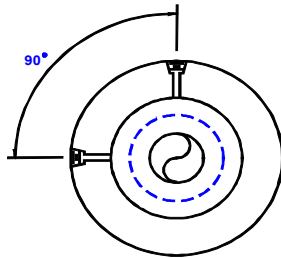

The Quadrant bore is machined with a rounded inlet edge. Any excess material is removed with a counter-bore on the downstream side of the plate.

\* Quadrant bores are designed for dirty, viscous and corrosive liquid

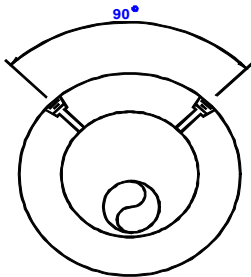

The Eccentric bore is machined off center. With the bottom of the bore setting inscribed within a circle equal to 98% of the pipe diameter.

\* Eccentric bores are designed for dirty gases/vapors and liquids with solids or slurries entrapped in the line.

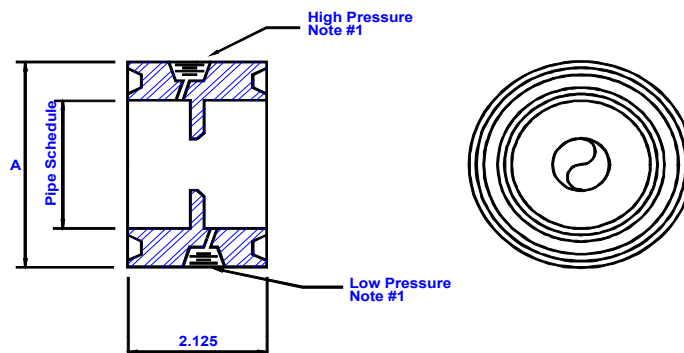

**Ring Joint Face Available**